

THIS DRAWING IS UNPUBLISHED. RELEASED FOR PUBLICATION .19
 © COPYRIGHT 19 BY AMP INCORPORATED. ALL INTERNATIONAL RIGHTS RESERVED.

REV	DATE	DESCRIPTION	APPD
4	04/07/93	ADDED -9 PER NPR 4680 AND REDRAWN ON CAD	-

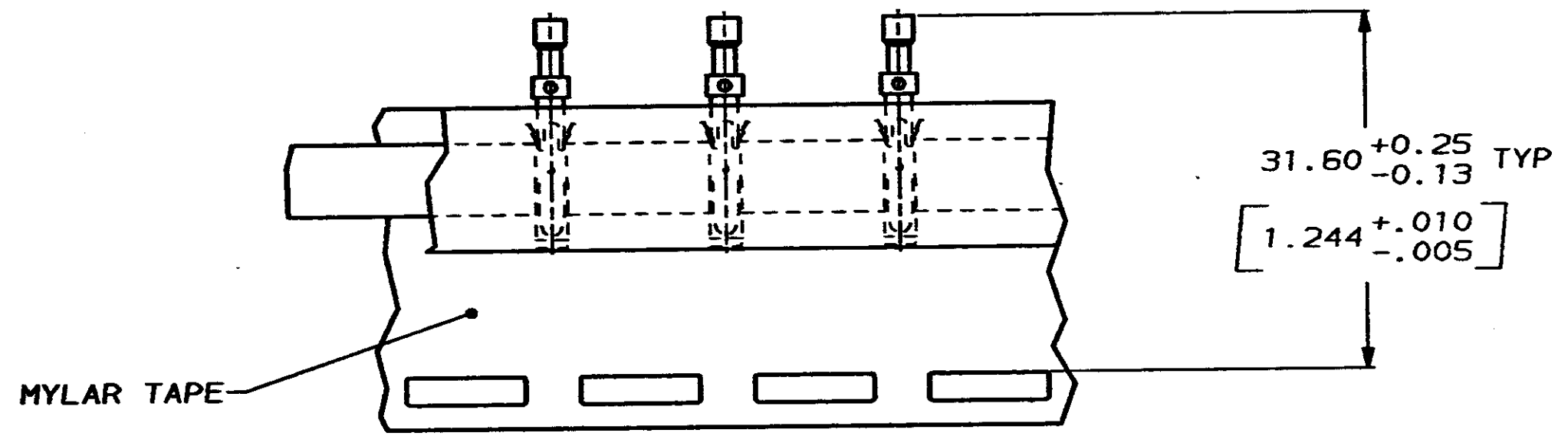
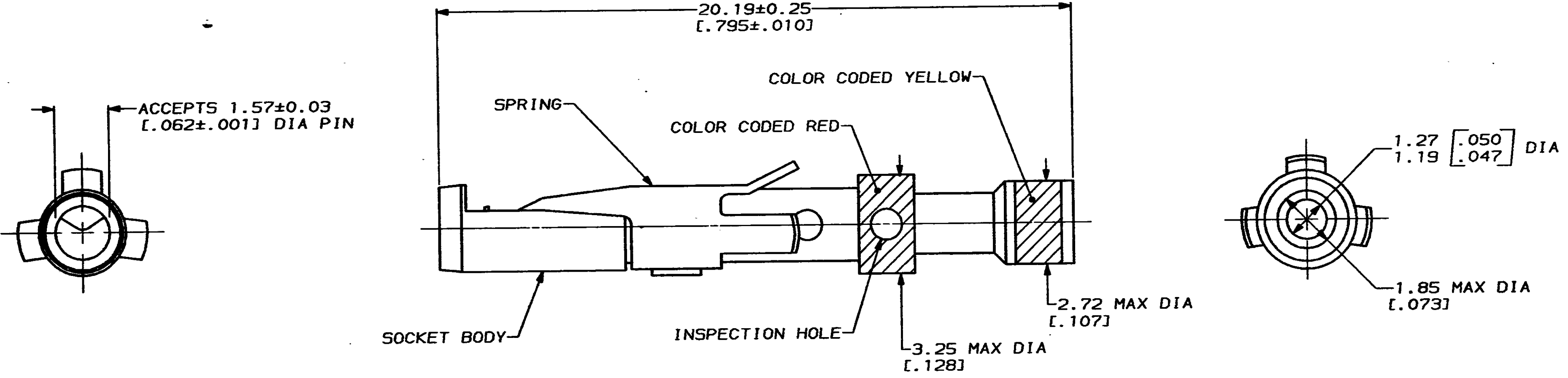

TAPE MTG DETAIL
SCALE 2:1

- 1 0.76µm [0.00030] MIN GOLD OVER 1.27µm [0.00050] MIN NICKEL.
- 2 2.54µm [0.00100] MIN GOLD OVER 1.27µm [0.00050] MIN NICKEL.
- 3 WHEN ORDERING CONTACT ASSEMBLY ON TAPE, ORDER BY THE TAPE NUMBER PLUS THE PACKAGING CODE AS FOLLOWS:
 1. FOR USE WITH AMP TAPETRONIC, PNEUMATIC TOOL-
 - A. 1000 PARTS TO A BOX ADD PACKAGING CODE: 1MBOX
 2. FOR USE WITH 4/8 INDENT STRIPPER CRIMPER-
 - A. 1000 PARTS TO A REEL ADD PACKAGING CODE: 1MREEL
 - B. 5000 PARTS TO A REEL ADD PACKAGING CODE: 5MREEL

PACKAGING TYPE	SOCKET BODY FINISH	PART NO
SMALL PACK	1	201580-9
TAPE MTG (SEE DETAIL) 3	2	201580-7
TAPE MTG (SEE DETAIL) 3	1	201580-4
STANDARD	2	201580-3
STANDARD	1	201580-1

DO NOT SCALE PRINT. UNLESS SPECIFIED DIMENSIONS IN mm [INCHES] TOLERANCES ON:	DR 04/07/93 D.GELTZ	AMP Incorporated Harrisburg, PA 17105-3608
2 PLC DEC ± -	CHK 4-26-93 R.STONE	
3 PLC DEC ± -	APPD 4-29-93 R.S.KLINE	
ANGLES ± -	APPD -	
MATERIAL	PRODUCT SPEC	NAME
SOCKET BODY: COPPER ALLOY	-	CONTACT ASSEMBLY, SOCKET, #16, 20-24 AWG, TYPE II
SPRING: STAINLESS STEEL	-	
FINISH	APPLICATION SPEC	SIZE
SOCKET BODY: SEE TABLE	-	C 00779
	WEIGHT	DRAWING NO
	-	C-201580
		SCALE 10:1
		SHEET 1 OF 1

THIS DRAWING IS A CONTROLLED DOCUMENT FOR AMP INCORPORATED. IT IS SUBJECT TO CHANGE AND THE CONTROLLING ENGINEERING ORGANIZATION SHOULD BE CONTACTED FOR THE LATEST REVISION.